

# **1187™**

## **IEEE Recommended Practice for Installation Design and Installation of Valve-Regulated Lead-Acid Storage Batteries for Stationary Applications**

### **IEEE Standards Coordinating Committee 29**

Sponsored by the  
IEEE Standards Coordinating Committee 29  
on Stationary Batteries



Published by  
The Institute of Electrical and Electronics Engineers, Inc.  
3 Park Avenue, New York, NY 10016-5997, USA

31 May 2002

Print: SH94985  
PDF: SS94985

# IEEE Recommended Practice for Installation Design and Installation of Valve-Regulated Lead-Acid Storage Batteries for Stationary Applications

Sponsor

**IEEE Standards Coordinating Committee 29  
on Stationary Batteries**

Approved 21 March 2002

**IEEE-SA Standards Board**

**Abstract:** This recommended practice provides guidance for the installation and installation design of valve-regulated lead acid (VRLA) batteries. This recommended practice is intended for all float-service stationary installations. However, specific applications, such as emergency lighting units and semiportable equipment, may have other appropriate practices and are beyond the scope of this recommended practice. Alternate energy applications are not covered.

**Keywords:** acceptance test, battery capacity, battery installation, battery installation design, battery maintenance, battery terminal voltage, battery testing, connection resistance measurements, float voltage, internal ohmic measurements, standby power applications, valve-regulated lead-acid battery

---

The Institute of Electrical and Electronics Engineers, Inc.  
3 Park Avenue, New York, NY 10016-5997, USA

Copyright © 2002 by the Institute of Electrical and Electronics Engineers, Inc.  
All rights reserved. Published 31 May 2002. Printed in the United States of America.

*Print:* ISBN 0-7381-3251-9 SH94985  
*PDF:* ISBN 0-7381-3252-7 SS94985

*No part of this publication may be reproduced in any form, in an electronic retrieval system or otherwise, without the prior written permission of the publisher.*

**IEEE Standards** documents are developed within the IEEE Societies and the Standards Coordinating Committees of the IEEE Standards Association (IEEE-SA) Standards Board. The IEEE develops its standards through a consensus development process, approved by the American National Standards Institute, which brings together volunteers representing varied viewpoints and interests to achieve the final product. Volunteers are not necessarily members of the Institute and serve without compensation. While the IEEE administers the process and establishes rules to promote fairness in the consensus development process, the IEEE does not independently evaluate, test, or verify the accuracy of any of the information contained in its standards.

Use of an IEEE Standard is wholly voluntary. The IEEE disclaims liability for any personal injury, property or other damage, of any nature whatsoever, whether special, indirect, consequential, or compensatory, directly or indirectly resulting from the publication, use of, or reliance upon this, or any other IEEE Standard document.

The IEEE does not warrant or represent the accuracy or content of the material contained herein, and expressly disclaims any express or implied warranty, including any implied warranty of merchantability or fitness for a specific purpose, or that the use of the material contained herein is free from patent infringement. IEEE Standards documents are supplied “**AS IS.**”

The existence of an IEEE Standard does not imply that there are no other ways to produce, test, measure, purchase, market, or provide other goods and services related to the scope of the IEEE Standard. Furthermore, the viewpoint expressed at the time a standard is approved and issued is subject to change brought about through developments in the state of the art and comments received from users of the standard. Every IEEE Standard is subjected to review at least every five years for revision or reaffirmation. When a document is more than five years old and has not been reaffirmed, it is reasonable to conclude that its contents, although still of some value, do not wholly reflect the present state of the art. Users are cautioned to check to determine that they have the latest edition of any IEEE Standard.

In publishing and making this document available, the IEEE is not suggesting or rendering professional or other services for, or on behalf of, any person or entity. Nor is the IEEE undertaking to perform any duty owed by any other person or entity to another. Any person utilizing this, and any other IEEE Standards document, should rely upon the advice of a competent professional in determining the exercise of reasonable care in any given circumstances.

Interpretations: Occasionally questions may arise regarding the meaning of portions of standards as they relate to specific applications. When the need for interpretations is brought to the attention of IEEE, the Institute will initiate action to prepare appropriate responses. Since IEEE Standards represent a consensus of concerned interests, it is important to ensure that any interpretation has also received the concurrence of a balance of interests. For this reason, IEEE and the members of its societies and Standards Coordinating Committees are not able to provide an instant response to interpretation requests except in those cases where the matter has previously received formal consideration.

Comments for revision of IEEE Standards are welcome from any interested party, regardless of membership affiliation with IEEE. Suggestions for changes in documents should be in the form of a proposed change of text, together with appropriate supporting comments. Comments on standards and requests for interpretations should be addressed to:

Secretary, IEEE-SA Standards Board  
445 Hoes Lane  
P.O. Box 1331  
Piscataway, NJ 08855-1331  
USA

Note: Attention is called to the possibility that implementation of this standard may require use of subject matter covered by patent rights. By publication of this standard, no position is taken with respect to the existence or validity of any patent rights in connection therewith. The IEEE shall not be responsible for identifying patents for which a license may be required by an IEEE standard or for conducting inquiries into the legal validity or scope of those patents that are brought to its attention.

The IEEE and its designees are the sole entities that may authorize the use of the IEEE-owned certification marks and/or trademarks to indicate compliance with the materials set forth herein.

Authorization to photocopy portions of any individual standard for internal or personal use is granted by the Institute of Electrical and Electronics Engineers, Inc., provided that the appropriate fee is paid to Copyright Clearance Center. To arrange for payment of licensing fee, please contact Copyright Clearance Center, Customer Service, 222 Rosewood Drive, Danvers, MA 01923 USA; +1 978 750 8400. Permission to photocopy portions of any individual standard for educational classroom use can also be obtained through the Copyright Clearance Center.

## IEEE-SA Trademark Usage/Compliance Statement

Proper usage of the trademark **IEEE Std xxxx-2002<sup>TM</sup>** is mandatory and is to be followed in all references of the Standard. The mark **IEEE<sup>®</sup>** is the registered trademark of the Institute of Electrical and Electronics Engineers, Inc., and must be used in bold type. It is to appear with the registered trademark symbol “<sup>®</sup>” the first time “**IEEE**” appears in the text. The use of “IEEE Std xxxx-200x” should include the trademark symbol “<sup>TM</sup>” (e.g., **IEEE Std xxxx-200x<sup>TM</sup>**) at least the first time it is used in text, unless the number of the standard is also trademark registered (e.g., **802<sup>®</sup>**), then the symbol “<sup>®</sup>” must be used.

It is not permissible to use the standard number alone or with “**IEEE**” to indicate conformance or compliance with the associated standard. The user of the Standard should contact the Manager, Standards Licensing and Contracts for information concerning issues regarding indicating product compliance with an **IEEE** standard. To represent that a product has been designed to meet an **IEEE** standard, it is permissible to state that “the product has been engineered, designed or manufactured with the intent to meet the requirements of **IEEE Std xxxx-200x<sup>TM</sup>**.” However, it is *not* permissible to state or refer to a product as “xxxx compliant,” “xxxx certified,” “**IEEE xxxx** conformant,” “**IEEE xxxx** certified,” or the like, unless the user has obtained a Certification License from the IEEE.

## Introduction

(This introduction is not part of IEEE Std 1187-2002™, IEEE Recommended Practice for Installation Design and Installation of Valve-Regulated Lead-Acid Storage Batteries for Stationary Applications.)

Valve-regulated lead acid (VRLA) batteries are playing an ever-increasing role in control and power systems. In many cases, VRLA batteries are being substituted for vented lead-acid batteries. Their use is also expanding into many other applications where their unique characteristics are desirable. Both gelled electrolyte and absorbed electrolyte VRLA designs, covering a range of sizes and capacities, are now available for use in many traditional and nontraditional battery applications. This recommended practice fulfills the need within the industry to provide a common understanding of VRLA batteries and is applicable to float-service stationary installations. Alternative energy applications are not covered.

This recommended practice was prepared by the IEEE 1187 Working Group, Installation and Maintenance Subcommittee of the Standards Coordinating Committee 29 on Stationary Batteries. At the time this recommended practice was completed, the IEEE 1187 Working Group had the following membership:

### **Eddie Davis, *Chair***

Curtis Ashton  
Richard T. Bolgeo  
Ron Burgin  
William Cantor  
Thomas Carpenter  
Jay Chamberlin  
Steve Clark  
Bruce Cole  
Garth Corey  
Dan Cox  
John Coyle

Thomas Croda  
Peter DeMar  
Mike Flack  
Robert Fletcher  
Paul Foley  
Daniel Funk  
Timothy Furlong  
Jerry Gordon  
Thomas Gorlitz  
Wayne Johnson  
Peter Langan  
Jose Marrero

James McDowall  
Nick Nichols  
Edward Rafter  
Thomas Ruhlmann  
Saba N. Saba  
Amiya Samanta  
Robert Schmitt  
Frank Tarantino  
Shawn Tyler  
Michael Weeks  
Walter Wylie

The following members of the balloting committee voted on this standard. Balloters may have voted for approval, disapproval, or abstention.

James Anderson  
Curtis Ashton  
Gary Balash  
Robert Beavers  
Richard T. Bolgeo  
William Cantor  
Jay Chamberlin  
Mark Clark  
Garth Corey  
John Coyle  
Eddie Davis  
Peter DeMar  
Harold Epstein

Robert Fletcher  
Daniel Funk  
Timothy Furlong  
Jerry Gordon  
Thomas Gorlitz  
Richard Greco  
Randall Groves  
Paul Houck  
J. H. Kelly  
Alan Lamb  
Peter Langan  
Daniel Levin  
Demetrios N. Logothetis  
Joel Long

Jose Marrero  
James McDowall  
Bansi Patel  
Hal Priestley  
Thomas Ruhlmann  
Saba N. Saba  
Amiya Samanta  
Richard Setchell  
Sam Shah  
Shawn Tyler  
Kurt Uhler  
Michael Weeks  
Walter Wylie

When the IEEE-SA Standards Board approved this standard on 21 March 2002, it had the following membership:

**James T. Carlo**, *Chair*

**James H. Gurney**, *Vice Chair*

**Judith Gorman**, *Secretary*

Sid Bennett  
H. Stephen Berger  
Clyde R. Camp  
Richard DeBlasio  
Harold E. Epstein  
Julian Forster\*  
Howard M. Frazier

Toshio Fukuda  
Arnold M. Greenspan  
Raymond Hapeman  
Donald M. Heirman  
Richard H. Hulett  
Lowell G. Johnson  
Joseph L. Koepfinger\*  
Peter H. Lips

Nader Mehravari  
Daleep C. Mohla  
William J. Moylan  
Malcolm V. Thaden  
Geoffrey O. Thompson  
Howard L. Wolfman  
Don Wright

\*Member Emeritus

Also included is the following nonvoting IEEE-SA Standards Board liaison:

Alan Cookson, *NIST Representative*

Satish K. Aggarwal, *NRC Representative*

Don Messina

*IEEE Standards Project Editor*

National Electrical Code and NEC are both registered trademarks of the National Fire Protection Association, Inc.

# Contents

1. Scope.....	1
2. References.....	1
3. Definitions .....	2
4. Safety .....	2
4.1 Protective equipment .....	3
4.2 Precautions.....	3
4.3 Procedures.....	3
5. Installation design criteria.....	4
5.1 Location .....	4
5.2 Mounting.....	5
5.3 Seismic.....	5
5.4 Ventilation .....	5
5.5 Instrumentation and alarms.....	6
5.6 Parallel-battery strings .....	7
5.7 Charger design .....	7
5.8 Battery protection .....	7
6. Installation procedures .....	8
6.1 Receiving and storage.....	8
6.2 Assembly .....	8
6.3 Freshening/initial charge and testing .....	10
6.4 Connection to dc system.....	10
6.5 Measuring ac ripple current .....	11
6.6 Measuring battery temperature and ambient temperature .....	11
6.7 Measuring battery charging current.....	11
7. Records .....	11
Annex A (informative) Bibliography .....	12
Annex B (informative) Thermal runaway.....	13
Annex C (informative) Effect of elevated temperature on expected battery life .....	14
Annex D (informative) Connection resistance measurements .....	16
Annex E (informative) Cell/unit internal ohmic measurements.....	22
Annex F (informative) Metric conversions .....	23

# IEEE Recommended Practice for Installation Design and Installation of Valve-Regulated Lead-Acid Storage Batteries for Stationary Applications

## 1. Scope

This recommended practice provides recommended design practices and procedures for storage, location, mounting, ventilation, instrumentation, preassembly, assembly, and charging of valve-regulated lead-acid (VRLA) storage batteries. Required safety practices are also included. This recommended practice is applicable to float-service stationary installations.

This recommended practice also contains six informative annexes. These provide additional tutorial information relating to topics introduced in the body of the document.

Battery sizing, maintenance, capacity testing, charging equipment, battery protection, and consideration of other types of batteries are beyond the scope of this recommended practice. Alternative energy applications are also beyond the scope of this recommended practice.

The portions of this recommended practice that specifically relate to personnel safety are mandatory instructions and are designated by the word *shall*; all other portions are recommended practices and are designated by the word *should*.

## 2. References

This recommended practice shall be used in conjunction with the following publications:

IEEE Std 485-1997™, IEEE Recommended Practice for Sizing Large Lead Storage Batteries for Generating Stations and Substations.<sup>1</sup>

IEEE Std 946-1992™, IEEE Recommended Practice for the Design of DC Auxiliary Power Systems for Generating Stations.

---

<sup>1</sup>IEEE publications are available from the Institute of Electrical and Electronics Engineers, 445 Hoes Lane, P.O. Box 1331, Piscataway, NJ 08855-1331, USA (<http://standards.ieee.org/>).

IEEE Std 1184-1994™, IEEE Guide for the Selection and Sizing of Batteries for Uninterruptable Power Systems.

IEEE Std 1188-1996™, IEEE Recommended Practice for Maintenance, Testing, and Replacement of Valve-Regulated Lead-Acid Storage Batteries for Stationary Applications.

IEEE Std 1189-1996™, IEEE Guide for Selection of Valve-Regulated Lead Acid (VRLA) Batteries for Stationary Applications.

IEEE Std 1375-1998™, IEEE Guide for the Protection of Stationary Battery Systems.

NFPA 70-1999, National Electrical Code® (NEC®).<sup>2</sup>

### 3. Definitions

For the purposes of this recommended practice, the following terms and definitions apply. *The Authoritative Dictionary of IEEE Standards Terms*, Seventh Edition [B1],<sup>3</sup> should be referenced for terms not defined in this clause.

**3.1 acceptance test:** Capacity test made on a new battery to determine that it meets specifications or manufacturer's ratings.

**3.2 internal ohmic measurements:** The measurement of either the internal impedance, conductance, or resistance of battery cells/units.

**3.3 recombinant:** Pseudonym for oxygen recombination. (IEEE Std 1189-1996™).

**3.4 terminal connection (battery):** Connections made between cells or rows of cells or at the positive and negative terminals of the battery, which may include terminal plates, cables with lugs, and connectors.

**3.5 unit (or module):** Multiple cells in a single jar or container.

**3.6 valve-regulated lead-acid (VRLA) cell:** A cell that is sealed with the exception of a valve that opens to the atmosphere when the internal gas pressure exceeds atmospheric pressure by a preselected amount. VRLA cells provide a means for recombination of internally generated oxygen and the suppression of hydrogen gas evolution to limit water consumption.

### 4. Safety

As with other batteries, VRLA batteries are potentially dangerous and proper precautions must be observed in handling and installation. Work on batteries shall be performed only by knowledgeable personnel with proper safe tools and protective equipment.

---

<sup>2</sup>NFPA publications are available from Publications Sales, National Fire Protection Association, 1 Batterymarch Park, P.O. Box 9101, Quincy, MA 02269-9101, USA.

<sup>3</sup>The numbers in brackets correspond to those in the bibliography in Annex A.

## 4.1 Protective equipment

Although VRLA cells can vent or leak small amounts of electrolyte, electrical safety is the principal, but not the only, concern for safe handling. The following equipment for safe handling of the battery and protection of personnel shall be available:

- a) Safety glasses with side shields, or goggles, or face shields, as appropriate
- b) Electrically insulated gloves, appropriate for the installation
- c) Protective aprons and safety shoes
- d) Portable or stationary water facilities in the battery vicinity for rinsing eyes and skin in case of contact with acid electrolyte
- e) Class C fire extinguisher
- f) Acid neutralizing agent
- g) Adequately insulated tools
- h) Lifting devices of adequate capacity, when required

### NOTES

1—Some battery manufacturers do not recommend the use of CO<sub>2</sub> fire extinguishers due to the potential of thermal shock.

2—Although VRLA cells are designed to minimize electrolyte leakage, neutralize any electrolyte with bicarbonate of soda mixed approximately 0.1 kg/L of water or other appropriate neutralizing agents.

## 4.2 Precautions

The following protective procedures shall be observed:

- a) Use caution when working on batteries because they present a shock and arcing hazard.
- b) Check the voltage to ground [alternating current (ac) and direct current (dc)] before working around the battery. Wear protective equipment suitable for the voltage.
- c) Prohibit smoking and open flame, and avoid arcing in the immediate vicinity of the battery.
- d) Provide adequate ventilation, and follow the manufacturer's recommendations during charging.
- e) Ensure unobstructed egress from the battery work area.
- f) Avoid the wearing of metallic objects such as jewelry while working on the battery.
- g) Ensure that work area is suitably illuminated.
- h) Follow the manufacturer's recommendations regarding cell orientation.
- i) Follow the manufacturer's instructions regarding lifting and handling of cells.
- j) UPS or other systems might not be equipped with an isolation transformer. In addition to dc voltage, an ac voltage might also be present. And lack of an isolation transformer may provide a direct path to ground of the dc supply to the UPS. This can substantially increase the electrocution and short-circuit hazards.

## 4.3 Procedures

The following safety procedures should be observed:

- a) Ensure battery racks or cabinets are adequately supported, stable, and secure. (Refer to 5.3.)
- b) Connect support structures to ground system in accordance with applicable codes.

- c) Inspect all flooring and lifting equipment for functional adequacy.
- d) Restrict all unauthorized personnel from the battery area.
- e) Keep the battery clear of all tools and other foreign objects.
- f) Avoid static buildup by having personnel contact ground periodically while working on batteries.
- g) Do not remove the pressure relief valves without the battery manufacturer's approval.
- h) Inspect and test instrumentation for safe working condition.

During the installation phase of a battery, consideration should be given to protecting the battery from workers performing tasks unrelated to the battery installation. The potential exists for debris and conducting materials to fall onto the battery. A protective covering with suitable impact and electrical insulating qualities can be beneficial for protecting the battery from an unqualified worker as well as for protecting unqualified workers from potential electric shock.

## 5. Installation design criteria

Considerations that should be included in the design of the battery installation depend on the requirements or function of the system of which the battery is part. The general installation design criteria for all VRLA batteries are provided in the following subclauses.

### 5.1 Location

#### 5.1.1 General criteria

The following general criteria should be considered:

- a) Space allocated for the battery and associated equipment should allow for present and future needs. Calculations should be performed to ensure that floor loading capabilities are not exceeded.
- b) The location should be as free from vibration as practical.
- c) The general battery area should be clean, dry, and ventilated. Provide adequate space and illumination for inspection, maintenance, testing, and cell/battery replacement. Space should also be provided to allow for operation of lifting equipment and taking measurements (e.g., voltages, resistances, etc.).
- d) The electrolyte in a VRLA cell is immobilized so that it is not a free liquid. Electrolyte immobilization provides a cell that will leak little or no electrolyte if damaged (refer to IEEE Std 1189-1996™). Furthermore, there is no requirement or provision for the user to add water or perform electrolyte maintenance. For the above reasons, spill containment is not necessary for VRLA battery installations.
- e) For personnel safety, portable or stationary water facilities shall be provided.
- f) Provisions for the safe handling and disposal of acid electrolyte shall be included in accordance with governmental regulations.
- g) Illumination in the battery area should equal or exceed the interior lighting recommendations in Figure 11.1 of [B2]. For smaller installations, portable lighting might be necessary to provide adequate illumination.

#### 5.1.2 Design for maintainability

The battery installation should be designed, located, and installed so that it is maintainable. Ensure the installation design provides adequate access to the terminals of each cell/unit for maintenance and testing while the battery is connected to the dc system on normal float charge operation.

A maintainable design is one in which the terminals of all cells/units are accessible during normal float operation for periodic maintenance and intercell connection resistance checks. Refer to IEEE Std 1188-1996™ for periodic maintenance recommendations; a maintainable installation will allow the IEEE Std 1188-1996™ maintenance recommendations to be performed. Static-resistive plastic covers that are designed for removal to allow maintenance access are acceptable. Examples of less maintainable designs include UPS systems in which each battery is sealed inside a cabinet without any provision for access or cells with fully insulated terminal covers that cannot be removed without also disconnecting the cell from the circuit.

Wherever possible, avoid installations containing parallel cells inside of a string of cells because the periodic maintenance recommendations provided in IEEE Std 1188-1996™ might not be achievable. For example, voltage and internal ohmic measurements might not represent the actual condition of each cell when taken on cells installed in parallel.

For batteries not installed inside cabinets or enclosures, ensure the installation provides working space clearances and guarding of live parts in accordance with NFPA 70, Article 480-8. For batteries inside cabinets or enclosures, a minimum working clearance of 200 mm is recommended around the cell or module terminals; slide out trays or other means of access should be considered.

## 5.2 Mounting

The most common practice is to mount cells on open racks or in enclosures. The designer should use structures of nonflammable or self-extinguishing materials.

Electrical connections to the battery and between cells on separate levels or racks should be made to minimize mechanical strain on battery terminal posts.

## 5.3 Seismic

When the installation is to be in a location subject to a high probability of seismic disturbance or where applicable building codes require seismic protection, the racks, enclosures, anchors, and installation thereof shall be able to withstand the calculated seismic forces. Contact the battery manufacturer for guidance regarding the selection and installation of the appropriate battery rack for the intended location and application.

### CAUTION

Anchoring a rack to both the floor and the wall may cause stress due to conflicting modes of vibration.

## 5.4 Ventilation

### 5.4.1 Ventilation for temperature control

The battery optimum operating temperature is 25 °C, as measured at the negative terminal post, and it is the basis for rated performance. The recombinant process in VRLA batteries produces heat during normal float. During steady-state conditions, VRLA batteries, especially when enclosed, operate at temperatures higher than the surrounding ambient. In a well-designed, properly ventilated system operating at 25 °C, this temperature rise should be barely perceptible. Furthermore, installation in a location with an ambient below the optimum operating temperature will affect sizing and performance (refer to IEEE Std 485-1997™). Therefore, a location should be selected where a temperature can be maintained that will contribute to

optimum battery life and performance. Consult the manufacturer regarding a specific installation. Lower than rated temperatures decrease battery capacity, whereas high temperatures shorten battery life and can contribute to thermal runaway. Although all batteries are susceptible to thermal runaway, VRLA cells are more sensitive to the conditions that lead to thermal runaway (refer to Annex B). Refer to Annex C for the expected effect of a higher-than-rated ambient temperature on battery life.

The location or arrangement of cells should result in no greater than a 3 °C temperature differential between cells within a series-connected string at a given time. Avoid conditions that result in spot heating or cooling, as temperature variations will cause the battery to become electrically unbalanced.

Wherever possible, ensure the installation allows for adequate air flow around each cell or module to allow for convective and radiative cooling. This can be achieved by a combination of spacing between cells or modules, and the design of the supporting structure.

#### 5.4.2 Ventilation for hydrogen control

In a VRLA cell operating in a fully recombinant mode, internally there will be a slow buildup of hydrogen gas. When the cell internal pressure exceeds the valve release pressure, the hydrogen gas will be vented into the atmosphere. The following battery operating conditions have the following hydrogen generation effects:

- a) Minimal gas emission: open circuit, discharge, and initial recharge (slight gas evolution can occur from cells on open circuit as a result of local action)
- b) Occasional gas emission: float charge (periodic venting as a result of grid corrosion and to the extent that the recombination efficiency is less than 100 percent)
- c) Potential for maximum gas emission: equalize charge and near end of recharge
- d) Maximum gas emission: overcharge

Under certain failure or extreme overcharge conditions (above the recombinant ability of the cell), VRLA batteries can evolve hydrogen at a maximum rate of  $1.27 \times 10^{-7} \text{ m}^3/\text{s}$  per ampere per cell at 25 °C at standard pressure.

Adequate ventilation shall be provided in order to prevent the possible accumulation of hydrogen. Ventilation provides air circulation to help prevent hydrogen from concentrating in explosive quantities. The ventilation system shall limit hydrogen accumulation to less than 2% of the total volume of the battery area/cabinet. Either natural or forced ventilation can be used. Nearby equipment with arcing contacts shall be located in such a manner as to avoid those areas where hydrogen pockets could form.

NOTE—Other applicable codes might be more restrictive than the above 2% requirement.

High temperatures in the battery area/enclosure result in increased hydrogen gas evolution. Refer to 5.4.1 for guidance regarding ventilation for temperature control.

### 5.5 Instrumentation and alarms

The following general recommendations for instrumentation and alarms apply to the battery installation only. Requirements for the charger, dc system design, and so on, are beyond the scope of this recommended practice.

Each battery installation should include the following instrumentation and alarms:

- a) Voltmeter
- b) High and low battery voltage alarm
- c) Ground fault detector (for ungrounded systems)

- d) Ammeter
- e) Battery or room high-temperature alarm (refer to Annex B)

#### NOTES

1—The preceding recommendations for instrumentation and alarms may be satisfied by equipment in the dc system.

2—Smaller installations often will not have all of the instrumentation listed above permanently installed. In these cases, provision should be made for the connection or use of portable test equipment.

### 5.6 Parallel-battery strings

When strings of cells or modules of equal voltage are connected in parallel, the overall capacity is equal to the sum of the capacities of the individual strings. Parallel strings are used in order to meet design requirements, such as

- a) Increasing the capacity of an existing battery
- b) Providing redundancy
- c) Providing battery reserve while a string is disconnected for maintenance or testing

When a VRLA battery consisting of parallel strings is necessary, the charging voltages of the individual strings must be compatible. In addition, each string should be equipped with disconnect capabilities for maintenance purposes, and for protection as appropriate for the application.

Parallel strings of single cells in series are preferable to the use of parallel cells within a single string. Refer to 5.1.2.

For constant-current charging applications, parallel strings are not recommended unless specifically approved by the battery manufacturer.

In general, there is no technical limit on the number of strings that can be used in parallel. However, there might be practical limits on the number of parallel strings, such as short-circuit current limits. Contact the manufacturer for further information.

### 5.7 Charger design

As a minimum, one battery charger and main distribution panel should be provided for each battery. The charger and the main power distribution center should be as close as practical to the battery, consistent with 5.4.

It is recommended that the charging system voltage applied to the battery be temperature compensated to the battery string temperature. Contact the battery manufacturer for the appropriate float voltage correction factor. Other methods of reducing or limiting charging current are available; contact the battery manufacturer.

### 5.8 Battery protection

Refer to IEEE Std 1375-1998™ for stationary battery protection design criteria. IEEE Std 1375-1998™ provides guidance applicable to the installation design of VRLA batteries, including the following:

- a) Types of protection
- b) Short-circuit characteristics of batteries

- c) Characteristics of protective devices
- d) Protection schemes
- e) Location and types of protective devices

## **6. Installation procedures**

Refer to Clause 4 for safety precautions to be followed.

### **6.1 Receiving and storage**

#### **6.1.1 Receiving inspection**

Upon receipt, and at the time of actual unloading, each package should be visually inspected for apparent damage and electrolyte leakage. If either is evident, a more detailed inspection of the entire shipment should be conducted and results noted on the bill of lading. Record receipt date and inspection data results, and notify manufacturer of any damage or follow the manufacturer's enclosed instructions.

#### **6.1.2 Unpacking**

- a) Never lift cells by the terminal posts.
- b) When lifting cells or modules, use the proper lifting equipment as recommended by the manufacturer.
- c) Check for evidence of leakage.
- d) All cells with visible defects such as cracked jars, loose terminal posts, or other unrecoverable problems shall be rejected.
- e) If the cells are installed in metallic containers, check the insulation resistance from the cells to the metallic containers. This can be performed with an insulation resistance tester by connecting one test lead to any post on the cell and connecting the other test lead on a bare metal spot on the metallic container. A minimum test voltage of 500 VDC and a minimum acceptable insulation resistance of 1 meg-ohms are recommended.

#### **6.1.3 Storage**

- a) Cells should be stored indoors in a clean, level, dry, ventilated, and cool location; extremely low ambient temperatures or localized sources of heat should be avoided. Typical storage temperatures range from 0 °C – 30 °C. Storage at elevated temperatures will increase the cell's self-discharge rate, which can require periodic freshening charges to correct. Refer to the battery manufacturer's literature for more information.
- b) Cells should not be stored for more than the time period recommended by the manufacturer without applying a charge to the battery.
- c) For charging during storage or special conditions, the battery manufacturer should be consulted. Record dates and conditions for all charges during storage.

## **6.2 Assembly**

### **6.2.1 Rack, enclosures, and modules**

Racks, enclosures, and modules should be assembled in accordance with the manufacturer's recommended procedures.

## 6.2.2 Cell mounting and connections

The following sequence may be used:

- a) Before proceeding with the installation, verify that, for each cell, the difference between the measured open circuit voltage and the manufacturer's published value is no greater than 0.1 V. For multi-cell units, the difference should be no greater than 0.1 V multiplied by the number of cells per unit. If any cell/unit does not meet this requirement, do not install that cell/unit before contacting the manufacturer for a proper course of action (e.g., single cell/unit charging or replacement)

NOTE—The 0.1 V limit stated above is based on a 1.300 specific gravity cell and corresponds to approximately a 50% state of charge.

- b) Before proceeding with the installation, verify that for each cell or module the difference between the manufacturer's published internal ohmic value for the specific model and the measured value is less than 30% outside the acceptable value. If the difference does exceed 30%, do not install that cell/unit before contacting the manufacturer (refer to Annex E).
- c) Clean dust and dirt off the cell covers and containers using a water-moistened clean wiper; do not use strong hydrocarbon-type degreasing agents or strong alkaline cleaning agents, which may cause containers and covers to crack or craze.

If electrolyte spillage or seepage is evident, it does indicate a problem. Contact the manufacturer for corrective action.

- d) Mount the cells/units as appropriate for the installation in accordance with the manufacturer's recommendations.
- e) Check cell polarity for positive to negative connections throughout the battery.
- f) Unless otherwise instructed by the manufacturer, clean all terminal posts and connecting hardware. The contact surfaces should be cleaned by rubbing gently with a nonmetallic brush or pad. Care should be exercised in cleaning to prevent removal of any plating. A thin film of manufacturer's approved corrosion-inhibiting compound should be applied to all contact surfaces. Intercell/interunit connections may now be made.
- g) When more than one intercell/interunit connector per terminal post is required, mount the intercell connectors on opposite sides of the terminal post for maximum surface contact. On cells with threaded terminal posts, the connectors are stacked.
- h) Tighten connector bolts to the battery manufacturer's recommended torque values. For nut and bolt assemblies, use a second wrench for counter torque. Use insulated wrenches.
- i) Read the voltage of the battery to ensure that individual cells are connected correctly (i.e., the total voltage should be approximately equal to the number of cells or units multiplied by the typical cell or unit voltage). If the measurement is less than expected, recheck the connections for proper polarity.
- j) For future identification, apply individual cell/unit numbers in sequence beginning with number one at one end of the battery; also add any required operating identification for strings. For parallel strings, the cells in each string should be numbered in the same polarity sequence starting with number one.
- k) Read and record intercell/interunit connection resistance and the method of measurement to determine the adequacy of initial installation, and as a reference for future maintenance requirements (refer to Annex D and Clause 7). For cables connected to the battery and for cables connected between cells, verify acceptable connection resistance between the lug and the cable conductor. Review records of each connection resistance measurement; remake and measure again any connection that has a resistance measurement more than 10% or 5 micro-ohms, whichever is greater, over the average for each type of connection (i.e., intercell, intertier, inter-rack, interunit). Check with the manufacturer for detailed procedures and expected values. Resistance measurements should be made between connected terminal posts of adjacent cells. Contact the manufacturer if the connection resistance cannot be brought to within the recommended guidelines.

**WARNING**

Because some resistance-measuring instruments may cause a spark when their probes are applied to the cell terminal posts, proper safety precautions shall be taken.

When items a) through k) have been satisfactorily completed, make connections from the battery to the charging system in preparation for the freshening charge.

### **6.3 Freshening/initial charge and testing**

#### **6.3.1 Freshening/initial charge**

Because a battery gradually loses some of its charge during shipment and storage, it may be necessary to apply a freshening charge during storage or upon installation.

Follow the manufacturer's instructions regarding the applied voltage and duration for a freshening charge. Periodically check the battery voltage, charge current, and temperature during the charge cycle. With constant-voltage charging, the charge current should gradually decrease during the charge and eventually stabilize at a low value. Observe the battery during the charge for unusual conditions. If the battery temperature rises more than 10 °C during the charge, stop the charge and investigate.

**CAUTION**

Do not equalize the battery unless specified by the manufacturer. Equalizing a VRLA battery could cause damage.

#### **6.3.2 Internal ohmic measurements**

After the battery is fully charged in accordance with the manufacturer's instructions and the battery environment has stabilized, measure and record the individual cell/unit internal ohmic values (refer to Annex E). These records may be used as baseline data (refer to Annex E). Consult the instrument manufacturer for proper use of the instruments.

#### **6.3.3 Acceptance test**

Perform an acceptance test in accordance with IEEE Std 1188-1996™.

### **6.4 Connection to dc system**

If not already connected to the dc system, connect the battery to the dc system at this time.

NOTE—If the battery is to be connected to an already energized and operational system, care and preplanning is recommended to prevent generating an arc or causing system voltage transients. It is recommended to minimize the voltage difference between the battery string and the bus before making the connection.

## 6.5 Measuring ac ripple current

Measure and record the ac ripple current. Assure that the value recorded is within the battery manufacturer's recommendation.

## 6.6 Measuring battery temperature and ambient temperature

After the temperature of the installation has stabilized, measure and record the temperature of the battery at the negative terminal posts. Measure and record the ambient temperature in the battery room and inside the enclosure, if used.

Ambient temperature inside cabinet-type enclosures may change rapidly when the doors are opened. In this instance, an attempt should be made to measure the temperature inside the cabinet without opening the doors.

## 6.7 Measuring battery charging current

After the battery is fully charged in accordance with the manufacturer's instructions and the battery environment has stabilized, measure and record the battery float charging current. This measurement should be made at a location in the battery string that includes the total charging current. This measurement should be made for each string.

## 7. Records

Data obtained from receiving, storage, and assembly are pertinent to the maintenance and operational life of the battery. The data that should be dated, recorded, and maintained in a suitable permanent file for record purposes and future reference include

- a) Receiving inspection data and conditions of charge [refer to 6.1.3, item c)]
- b) Initial resistance values of the intercell connections [refer to 6.2.2, item j)]
- c) Individual cell/unit voltage values at the completion of the freshening/initial charge
- d) Individual cell/unit internal ohmic values, instrument type, test probe locations, system conditions, (i.e., on-line/off-line, float, etc.) and the cell/unit surface negative terminal post temperature at the time of the measurement
- e) Acceptance test data
- f) Initial ripple current
- g) Battery temperature and ambient temperature
- h) Battery charging float current for each string

The preceding records should be in accordance with cell/unit identification [refer to 6.2.2, item i)].

## **Annex A**

(informative)

### **Bibliography**

[B1] IEEE 100™, *The Authoritative Dictionary of IEEE Standards Terms*, Seventh Edition.

[B2] *Illuminating Engineering Society of North America Lighting Handbook*, Reference and Application, 1993.

## Annex B

(informative)

### Thermal runaway

When a VRLA cell is operating on float or overcharge in a fully recombinant mode, there is virtually no net chemical reaction and almost all of the overcharge energy results in heat generation. If the design of the system and its environment are such that the heat produced can be dissipated and thermal equilibrium can be reached, then there is no thermal runaway problem. However, if the recombination reaction gives rise to a rate of heat generation that exceeds the rate of heat dissipation, the battery temperature will rise and more current will be required to maintain the float voltage. The additional current results in still more recombination and heat generation, which further raises battery temperature and so on. The net effect can be accelerated dry out or melting of the battery. This potential problem is further aggravated by elevated ambient temperatures or by cell charging system malfunctions. The possibility of thermal runaway may be minimized by use of appropriate ventilation between and around the cells and by limiting the charger output current and voltage such as by using temperature compensated chargers. In the gelled electrolyte system, the gel has intimate contact with the plates and container walls and provides better heat dissipation characteristics than does the absorbed electrolyte system, but not as good as the vented (“flooded”) system.

Conditions that can lead to or contribute to thermal runaway include the following:

- High operating ambient without compensation of float voltage or other methods of controlling charge current
- Improper float voltage adjustment
- Individual cell failure within a battery string
- Charger failure resulting in high output voltage, current, or ripple
- Oversized or excessive number of chargers (which would supply too much recharge current)
- Insufficient cell/unit spacing or ventilation
- Older cells that can support recombination at a higher current level

In an uncorrected thermal runaway condition:

- High charging current and recombination inefficiencies result in excessive gas evolution, venting, eventual dry out, and failure.
- Ultimately cells vent, dry out, and fail. When charging current is at maximum levels, the battery temperature can cause cell meltdown leading to a fire or explosion.

The likelihood of thermal runaway can be minimized through periodic inspections and the use of temperature-compensated charging (or other charge-current-limiting methods).

#### NOTES

1—Because hydrogen and oxygen will be vented from the cells, enclosures shall be designed with sufficient ventilation to limit gas concentrations to a safe level.

2—Due to the possibility of fire resulting from thermal runaway, the use of self-extinguishing materials is recommended.

## Annex C

(informative)

### Effect of elevated temperature on expected battery life

It is accepted that VRLA batteries are more sensitive to temperature variations than are vented cells, but quantitative values have not been determined. Figure C.1 shows the effect of temperature on battery life for vented cells; this figure is based on a 50% reduction in expected service life for every 8.3 °C increase in temperature. Figure C.1 should be used as a guide to estimate the minimum expected reduction in life as a function of a higher average service temperature.

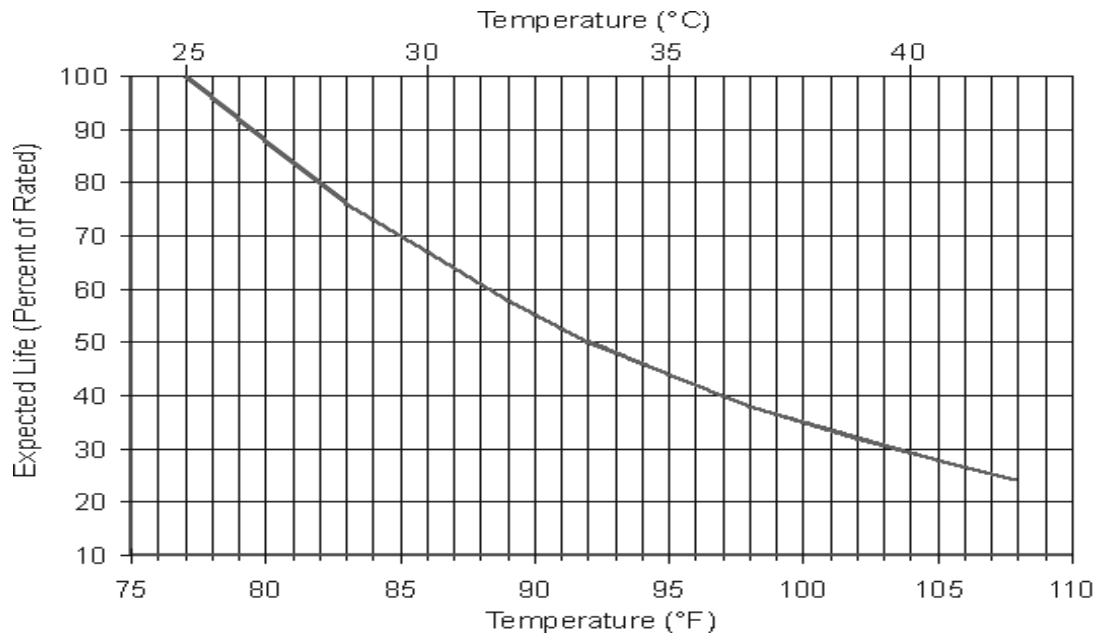

**Figure C.1—Effect of temperature on expected battery life**

Seldom does a battery remain at the same temperature throughout the entire year. The following formula integrates annual variations by calculating the months at elevated temperatures versus months of life at normal (25 °C) temperatures. The number of intervals used in Equation (C.1) depend on the observed temperature fluctuation; more intervals should be used if the temperature variation is significant.

$$Lt_c = \left[ \frac{\text{Rated Life}}{\left( \frac{1}{L_1} \times \text{months @ } T_1 \right) + \left( \frac{1}{L_2} \times \text{months @ } T_2 \right) + \dots + \left( \frac{1}{L_n} \times \text{months @ } T_n \right)} \right] \quad (\text{C.1})$$

where

- $Lt_c$  is the expected service life in years corrected for temperature variations
- $L_n$  is the percent life from Figure C.1, expressed as a fractional value, for each temperature

$T_n$  is the temperature for each time period  
 months @  $T_n$  is the number of months at temperature  $T_n$   
 Rated Life is the expected service life expressed in months under ideal conditions at 25 °C

NOTE—The total months corresponding to  $T_1, T_2, \dots, T_n$  must equal 12 (one year)

Example: The electrolyte temperature at installation “Y” is 32.8 °C for 4 months, 30 °C for 4 months, and 25 °C for 4 months during a year. For this example, the expected service life at 25 °C is 120 months (10 years). Referring to Figure C.1, the expected service life for this temperature variation is as follows [Equation (C.2)]:

$$Lt_c = \left[ \frac{120}{\left(\frac{1}{0.52} \times 4\right) + \left(\frac{1}{0.67} \times 4\right) + \left(\frac{1}{1} \times 4\right)} \right] = \frac{120}{(7.69) + (5.97) + (4)} = 6.8 \text{ years} \quad (\text{C.2})$$

If the user chooses to operate the battery at the elevated temperatures described in this example, the design life can be expected to drop from 10 years to 6.8 years.

## Annex D

(informative)

### Connection resistance measurements

It is a good practice to measure and record intercell and terminal post connection resistances as baseline values upon installation. It is very important that the measurement procedure be consistent so as to detect upward changes that could be caused by corrosion or loose connections. Increased resistance is a cause for concern and may require corrective action. Connection resistance measurements are particularly important for high-rate applications in which each connection must be capable of carrying a high current.

#### D.1 General recommendations

Normal intercell/block resistances vary greatly as a function of the size of the installation (e.g., from less than 10 micro-ohms for a large battery to as much as 100 micro-ohms or more for a smaller battery). The manufacturer should be contacted for the expected values.

When taking micro-ohmmeter measurements, the test probes should be held perpendicular to the battery post. The measurements should be taken from the terminal post of a cell to the terminal post of the adjacent cell, as shown in Figure D.1, or from the terminal post to the terminal lug, depending on the configuration.

NOTE—Do not record the measurements in milliohms. All measurements should be acquired with the test instrument set to the lowest resistance scale and all measurements should be recorded in micro-ohms.

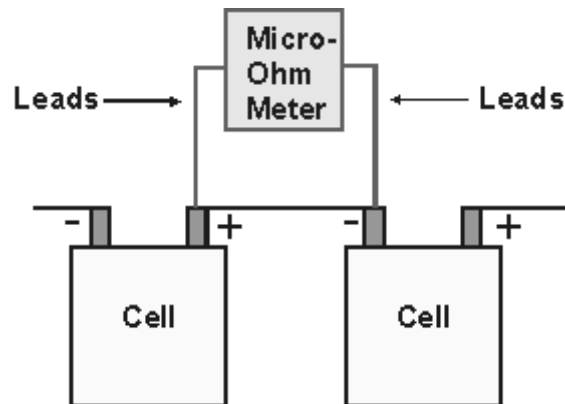
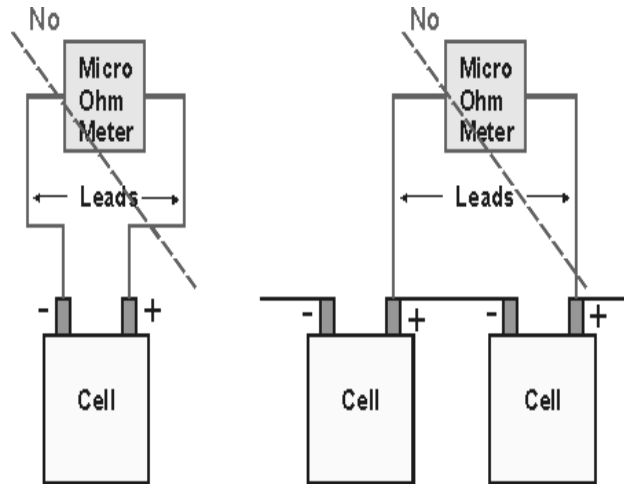

Figure D.1—Proper connection points

#### CAUTION

Do not take measurements across the cell. This improper action could cause personal injury, damage to the test equipment, and damage to the cell. Refer to Figure D.2 for examples of improper test connections.

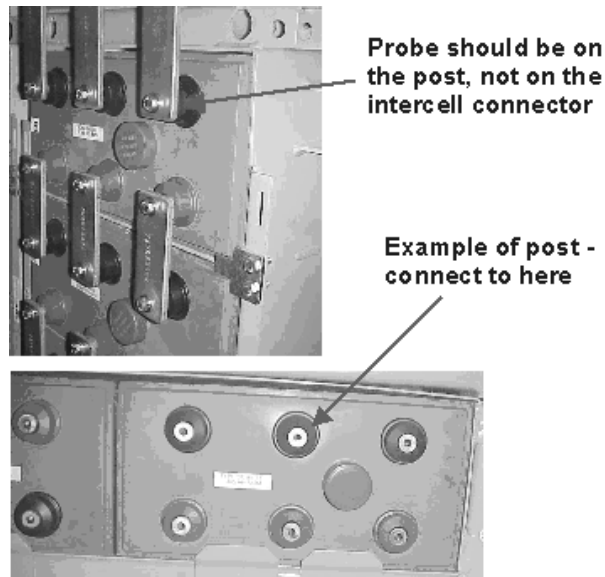

**Figure D.2—Improper connection points**

**CAUTION**

A voltage can also be present between a terminal post and earth ground. Do not touch the micro-ohmmeter leads to a cell terminal and the metal battery rack at the same time.

The desired contact point for each micro-ohmmeter probe is on the terminal post rather than on the intercell connection hardware (refer to Figure D.3). Depending on the cell design, it might be difficult to obtain measurements directly onto the terminal post. If this is the case, contact the battery manufacturer for guidance.



**Figure D.3—Probe contact on the post**

## D.2 Single and parallel intercell connections

Single and parallel intercell connections consist of an intercell connector terminated on each end to a single terminal post. Refer to Figure D.4 through Figure D.7 for examples of this configuration.

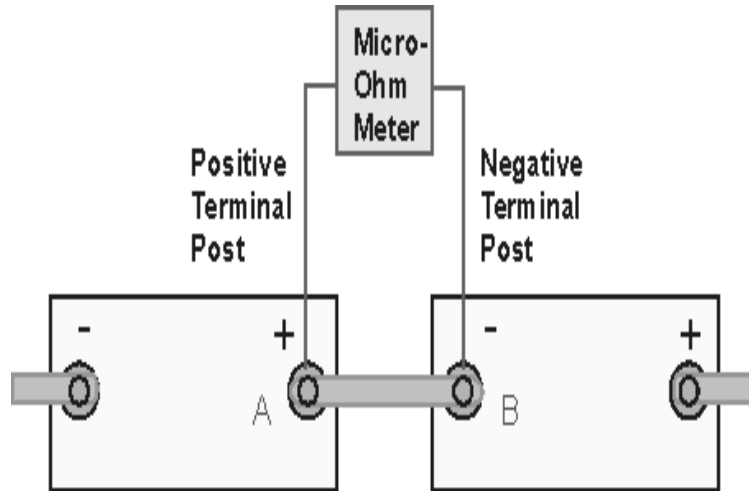

Figure D.4—Single intercell connection

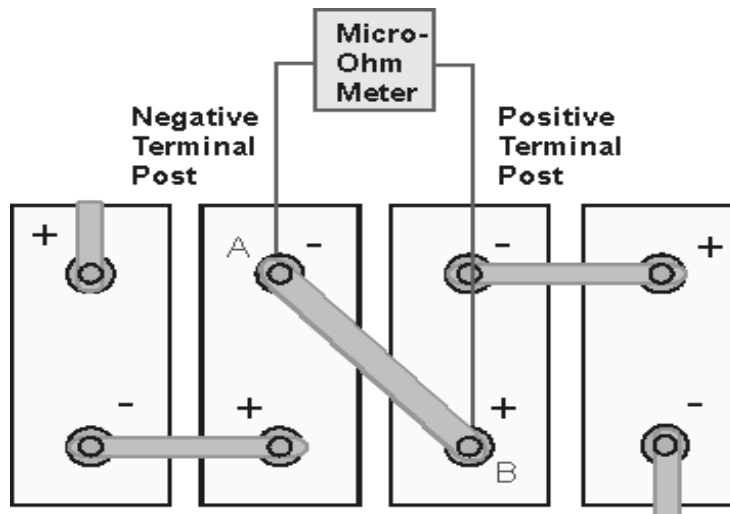
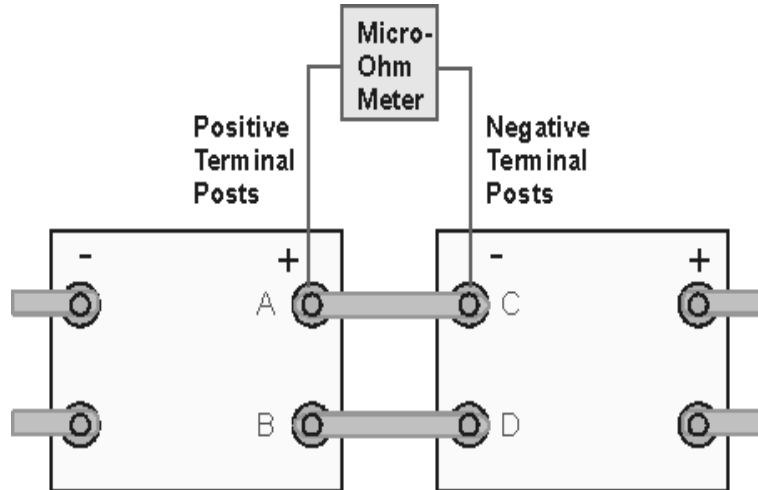

Figure D.5—Single intercell connection, diagonal post arrangement

For cells with a single positive and negative terminal post, as shown in Figure D.4 and Figure D.5, measure the intercell connection resistance of each intercell connection by measuring from the positive terminal post to the negative terminal post of the adjacent cell. Record the measurements.

If there are two positive and two negative terminal posts, as shown in Figure D.6, measure and record the intercell connection resistance of each intercell connection by measuring from

- a) Terminal post A to terminal post C
- b) Terminal post B to terminal post D



**Figure D.6—Parallel intercell connection, two posts**

If there are three positive and three negative terminal posts, as shown in Figure D.7, measure and record the intercell connection resistance of each intercell connection by measuring from

- a) Terminal post A to terminal post D
- b) Terminal post B to terminal post E
- c) Terminal post C to terminal post F

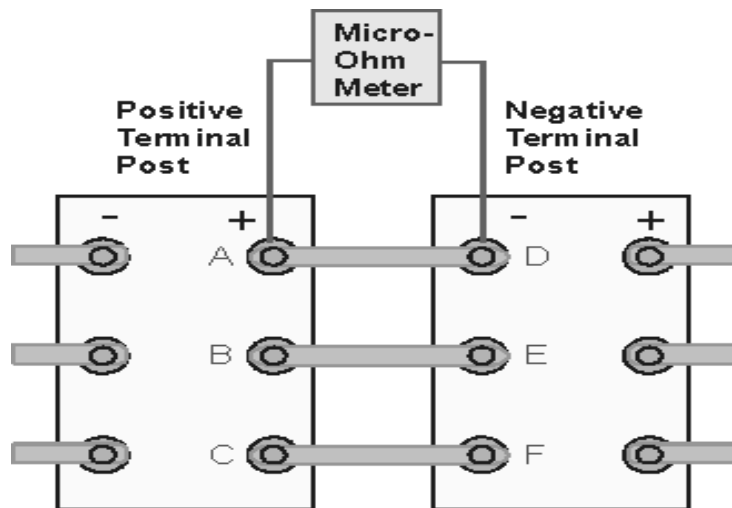

**Figure D.7—Parallel intercell connection, three posts**

### D.3 Multiple post-intercell connections

Multiple post-intercell connections consist of the intercell hardware connected on each end to more than one terminal post. Figure D.8 shows an example of this configuration.

Referring to Figure D.8 for a double post configuration, measure the intercell connection resistance of each intercell connection by measuring from

- a) Terminal post A to terminal post C
- b) Terminal post B to terminal post D

Record the measurements. If the cell design has more than two terminal posts, follow the same general process described above.

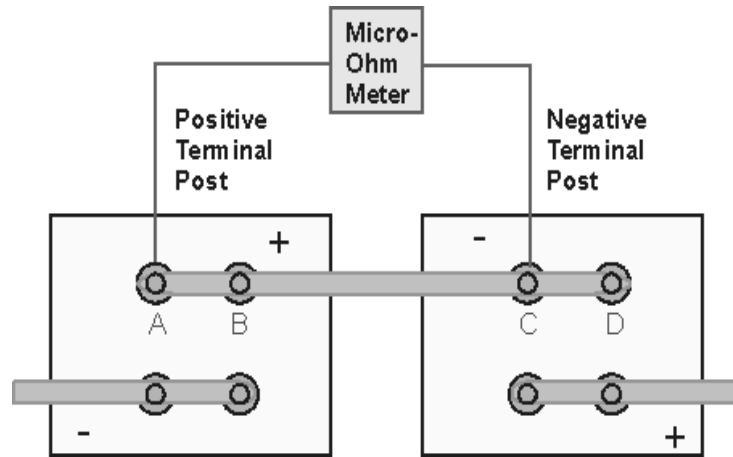

Figure D.8—Double terminal post-intercell connection

#### D.4 Single terminal connections

Single terminal connections consist of a connection resistance measurement from the post to a suitable point onto the connecting hardware. Refer to Figure D.9.

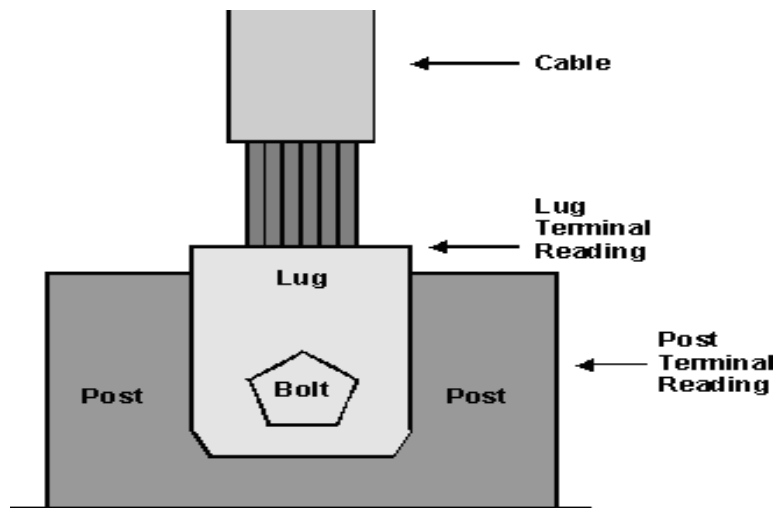

Figure D.9—Single terminal connection

Measure the terminal connection resistance of single terminal connections by measuring from the terminal lug to the terminal post. If there are multiple posts, repeat the measurement for each connection. Record the measurements.

## D.5 Connections involving cables

An intercell connection involving a cable is similar in approach to the methods described in the previous clauses (refer to Figure D.10). The principal difference is that the conductor resistance adds to the overall measurement in the terminal post to terminal post measurement. For this reason, the connection resistance should also be checked from each terminal post to its associated lug.

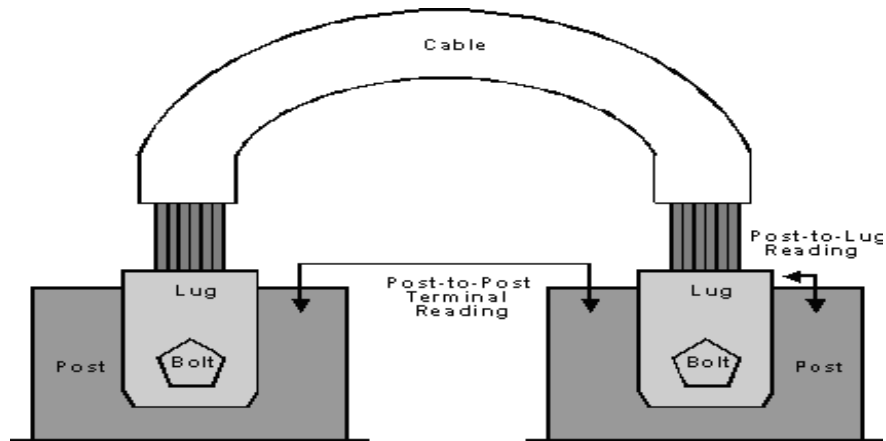

Figure D.10—Single intercell connection with cable

If there are multiple conductors attached to the terminal post(s) by means of a mounting plate or other arrangement, follow the same general process described above for a single conductor. Ensure that every connection resistance is measured and recorded.

## Annex E

(informative)

### Cell/unit internal ohmic measurements

These measurements provide information about cell internal impedance, resistance, or conductance and can be used for comparison between cells and for future reference.

The internal impedance of a cell consists of a number of factors, including the physical connection resistances, the ionic conductivity of the electrolyte, and the activity of electrochemical processes occurring at the plate surfaces. With multicell units, there are additional contributions due to intercell connections.

The techniques for measuring internal ohmic values are not standardized, and in many cases, the techniques are proprietary. However, the basic goal of these measurements is to provide some form of consistent method to quantify the internal ohmic value. The fundamental principle behind the measurement is to inject a signal into the cell and measure the resultant response. Different manufacturers use various frequencies and amplitudes and interpret the resultant signal differently. IEEE endorses no particular technique or manufacturer; users should select equipment based on their particular needs and proven results.

Initial measurements should be recorded for each cell/unit as follows:

- Type/model of internal ohmic test equipment used
- Test probe connection point or method
- Cell/unit measured internal ohmic value
- Cell/unit voltage
- Cell/unit temperature measured at negative terminal post

NOTE—Initial measurements should be taken on fully charged cells.

The initial internal ohmic measurements can be valuable for the following:

- a) Initial evaluation of cells/units: In rare cases, new cells may have problems, such as shorts, opens, or other defects. In this case, the problems might be identified by the initial internal ohmic measurements. If a cell/unit has an initial reading more than 30% different from the average reading, consult the battery manufacturer for acceptable values for that cell type and size.
- b) Future comparison and trending: The initial internal ohmic measurements may be used as baseline measurements for future comparison and trending. However, the internal ohmic values might change over the first few months of service as the battery stabilizes in float service. In this case, more representative baseline values might be obtained after the battery has been in service for some time. Refer to IEEE Std 1188-1996™ for subsequent periodic internal ohmic measurements.

## Annex F

(informative)

### Metric conversions

In 1995, IEEE implemented a new metric policy, which calls for measured and calculated values of quantities to be expressed in metric units [SI (Système International d'Unités)] in IEEE publications as of January 2000. This means that all new standards and revised standards submitted for approval shall now use SI units exclusively in the normative portions of the standard. For this reason, this annex provides conversions for non-SI units that are still widely used in the stationary battery industry.

To Convert From	To Convert To	To Multiply By
degree Celsius (°C)	degree Fahrenheit (°F)	$(°C \times 1.8) + 32$
Examples: $0\text{ °C} = 32\text{ °F}$ $10\text{ °C} = 50\text{ °F}$ $25\text{ °C} = 77\text{ °F}$ $30\text{ °C} = 86\text{ °F}$		
kilogram (kg)	pound (lb)	2.20
liter (L)	gallon (g)	0.26
Example: $0.12\text{ kg/L} = 1\text{ lb/gal}$ (such as 1 lb bicarbonate of soda to 1 gal of water)		
cubic meter (m <sup>3</sup> )	cubic foot (ft <sup>3</sup> )	35.31
second (s)	minute (min)	0.01667
Example: $1.27 \times 10^{-7}\text{ m}^3/\text{s} = 0.000269\text{ ft}^3/\text{min}$		
millimeter (mm)	inch (in)	0.03937
Examples: $13\text{ mm} = 0.51\text{ in}$ $200\text{ mm} = 7.87\text{ in}$		